

FR-100

**MINI HAND HELD TYPE 5 BANDS
COMMUNICATIONS RECEIVER**

USER'S OPERATION MANUAL



CONTENTS

| | PAGE |
|-------------------------------------|-------------|
| ■ DESCRIPTION OF FEATURES | 4 |
| -DISPLAY PANEL FEATURES | 4 |
| -TOP PANEL FEATURES | 5 |
| -SIDE AND BACK PANEL FEATURES | 6 |
| -FRONT PANEL FEATURES | 7 |
| ■ BATTERY PACK INSTRUCTION | 13 |
| ■ SPECIFICATION | 14 |

Caution : Any changes or modifications in construction of this device which are not expressly approved by the party responsible for compliance could void the user's authority to operate the equipment.

■ DESCRIPTION OF FEATURES

● *Display Panel Features*

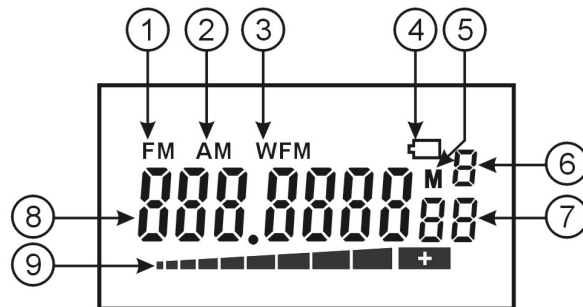

1. "FM "
Indicates the narrow "FM" mode has been selected.
2. "AM "
Indicates the "AM" mode has been selected.
3. "WFM "
Indicates the wide "FM" mode for broadcasting radio has been selected.
4. "  " (Battery indicator)
Indicates batteries are getting low. If the battery level is lower than the standard point, Battery Level Indicator will twinkle.
5. " M "
Indicates the memory mode has been selected.

Indicates that memory mode has been activated

6. "E" (A.b.c.d.E)

Indicates the operating band

7. "88" Memory channel indicator

Displays the memory channel number
(30 memories available per memory bank).

8. Channel (Frequency) indicator

Displays Frequency Number.

9. "■■■■■■■■■■+" S-RF (Signal strength indicator)

The radio incorporates a ten segment incoming signal on the LCD.
On receiving a signal, the meter will indicate how strong the signal is.
A weak signal will be indicated by one or two segments, while a very strong signal will have 8 to 10 segments.

● **Top Panel Features**

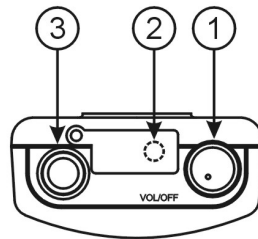

1. Power On/Off, Volume

Turn the Volume switch clockwise to turn power on and set desired volume. Turn the Volume button anti-clockwise to turn the power off.

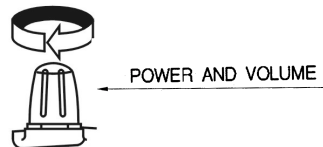

When the power is on, the lastly used frequency per mode and band is displayed on the LCD.

2. Antenna

This antenna provides good receiver performance given its overall size.

3. Phone Jack

Let the user listen to the conversation in privacy.

Dust Cover : When Earphone is not being used, this prevents dirt and moisture from getting inside the radio.

- **Side and Back Panel Features**

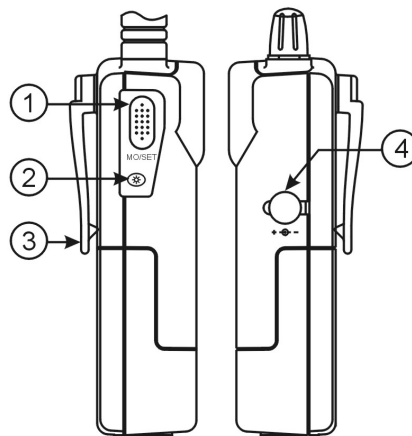

1. MO/SET (Monitor)

- 1) MO(Monitor)
Press the "MO(Monitor)" button shortly in the receiving mode to open the squelch control. This is useful when a weak signal is to be monitored.
Re-Activate : Press the MO button one more time.

- 2) SET
To fix each selection. Press this button.

2. ☼ (Lamp)

Press the "☼" button, the lamp will stay on for four seconds, after that it will turn off automatically. If you press another button on the front cabinet when the lamp is on, the lamp will stay on for four seconds from that time. If you press the "☼" button for more than one second, the beep will be Come and the lamp will stay on until you press the "☼" button once again.

3. Belt Clip

Allows for ease of carrying while attached to user's belt.

4. DC Jack

Allows for using external DC Power supply.

● Front Panel Features

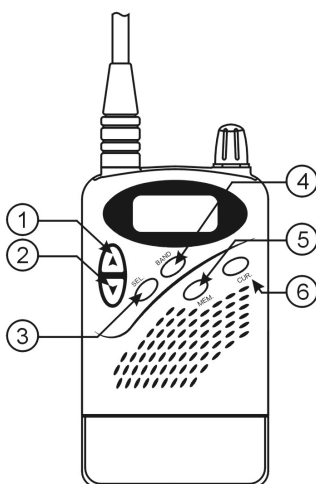

1. ▲ (Channel up) button

Press the "▲" button to move to a higher frequency than is currently shown on the LCD.

To access Up scanning process, press the "▲" button over two seconds.

In the event that during the scanning processing, the radio stop for 3 seconds at a receiving frequency and re-starting the scanning

- processing unless you press any buttons.
- If you want to stop scanning process, simply press any button
 - The scanning processing is available per band.

2. ▼ (Channel Down) button

Press the "▼" button to move to a lower frequency than is currently shown on the LCD.

To access Down scanning process, press the "▼" button over two seconds. In the event that during the scanning processing, the radio stop for 3 seconds at a receiving frequency and re-starting the scanning processing unless you press any buttons.

- If you want to stop scanning process, simply press any button
- The scanning processing is available per band.

3. SEL button

1) Select the mode

To select the wanted mode, pressing "SEL" button. Each mode will be accessed with following turn.

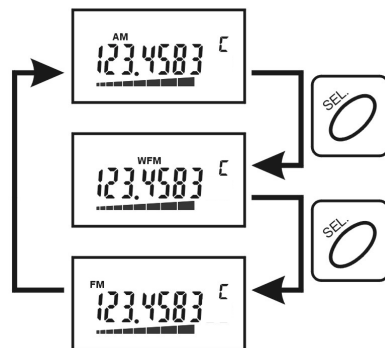

2) Adjust SQL Level

To adjust SQL level, press the "SEL" button longer than 2 seconds. With Up/Down button, you can adjust SQL level which you want. SQL level will be displayed with S-RF level meter. SQL level will be adjusted from S2 to S8.

3) Change of Frequency step

FR-100 has 5KHz, 8.33KHz(Air), 10KHz, 12.5KHz, 20KHz, 25KHz,

50KHz, 100KHz, 200KHz and 1MHz frequency step.
To change the frequency step, press the "SEL" button in the SQL level adjustment mode.
With Up/Down button, you can select the frequency step which you want. To fix the frequency step, press the "MO/SET" button.
If the "MO/SET" key will not be pressed over 4 seconds, current frequency step will be fixed automatically.

Note : The changed frequency step is only available per related band

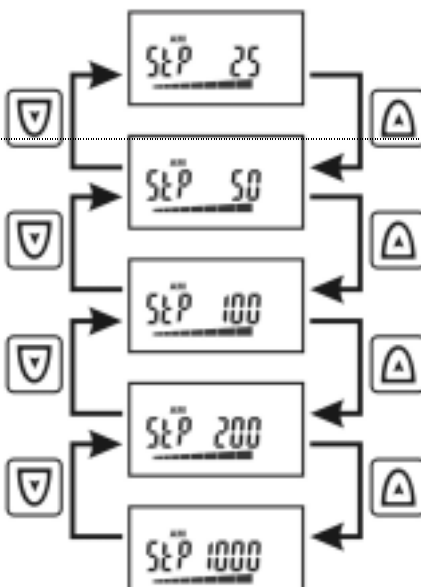
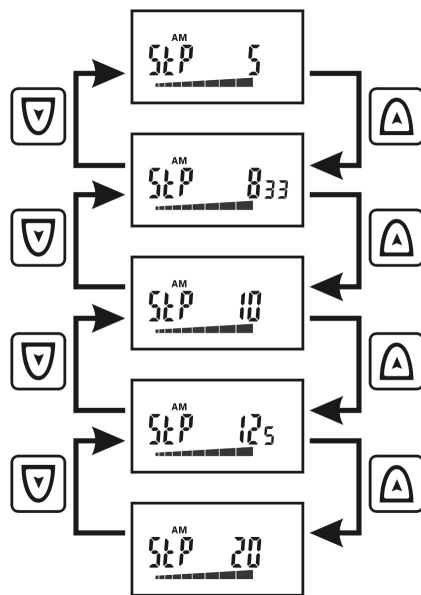

4. Band Button

FR-100 has five bands.

| | |
|---|--------------|
| A Band : 66 - 88 NFM(Narrow FM) | 25KHz Step |
| b Band : 88 - 108 WFM (Wide FM Broadcasting) | 100KHz Step |
| C Band : 108 - 137 AM | 25KHz Step |
| d Band : 137 - 174 NFM | 20KHz Step |
| E Band : 420 - 470 NFM | 12.5KHz Step |

To select the wanted band, pressing "BAND" button. Each band will be accessed with following turn.

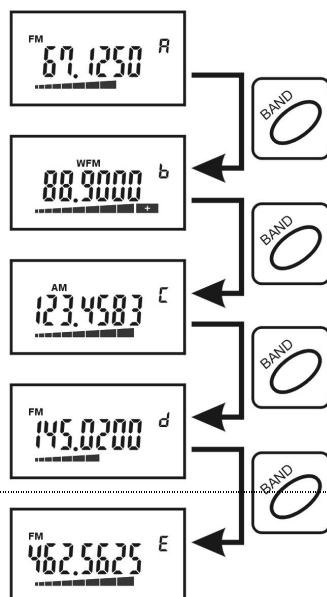

When you press the "BAND" button, the last used frequency per band will be displayed on the LCD.

5. MEM button

This FR-100 receiver contains a 30 memory locations for each band where desired frequencies can be programmed by the user.

1) Frequency Memory

Programming of the desired frequencies memory can be carried out in the following ways.

-
- Select the frequency which you want by using "SEL,BAND and Frequency Up/Down" button"
 - Press "MEM" button longer than 2 seconds
 - The LCD will show the empty memory channel location
 - Select the memory location where you wish to store the selected frequency by pressing "▲ or ▼ " buttons till the Memory Channel Indicator shows that location.
 - Press the "SET" button.

- Note : 1. If the "MO/SET" key will not be pressed over 4 seconds, current frequency will be stored automatically.
2. When the selected frequency is stored, the being used mode and step are also stored automatically.

2) Memory Recall

To access the memory recall,
- Press "MEM" button simply
- Select the memory location where you wish to find the stored frequency by pressing "▲ or ▼ " buttons till the Memory Channel Indicator shows that location.

- To Deactivate : Press "MEM" button simply

Note : If you want to use the stored frequency in normal mode, press "MEM" button longer than 2 seconds.

3) Memory Scan

To access the memory scan
- Enter the Memory Recall mode by pressing "MEM" button

- Pressing "▲" or "▼" buttons longer than 2 seconds
- The empty memory channels are skipped during scanning processing.
- To stop scanning, press any button.

4) Deletion of stored frequency

To access the deletion of memory

- To enter memory mode
- Select the memory channel which you want to delete
- Press "MO/SET" button longer than 2 seconds
- "ErASER" will appear on the LCD
- Press the "MO/SET" button one more time. With beep, the stored frequency in the memory channel will be erased.

5) Delete all stored frequency in the memory channel

To access it :

- Turn the power off
- Press and hold "SET" button
- Turn the power on.

6. CUR.(Cursor) button

The desired frequency can be directly entered using the cursor function in normal mode. The desired frequency however should be in the allocated frequency range of the band. To enter the frequency directly using cursor function, follow the example:

1) Example of Frequency selection

Frequency desired is 145.4650 MHz on the VHF Band.

- Press the "BAND" button till the VHF FM Band is indicated, then press "CUR" button. the first digit of the frequency display will start to flash. Now press "▲" or "▼" button to set the value to "1":
- Press the "CUR" button, the second digit of the frequency display will start to flash. Now press "▲" or "▼" button to set the value to "4":
- Continue this process for the remaining digits until you have entered the desired frequency.

NOTES : If you have selected a frequency which is above or below the frequency range allowed, the unit will automatically go to either the maximum or minimum frequency allowed per band and the mode is also changed.

■ BATTERY PACK INSTRUCTION

1. Press down the battery lock button on the bottom side of the radio.(①)
2. Open the battery cover on the back side of the radio.(②)
3. Install the battery as like shown.(③)
4. Put on the battery cover.(④)
5. Press the battery lock button upward to lock the battery case.

To supply the power, use the DC charge adapter.

CAUTION : Please use only rechargeable battery with DC charge adapter.
(Do not use dry battery with DC charge adapter)

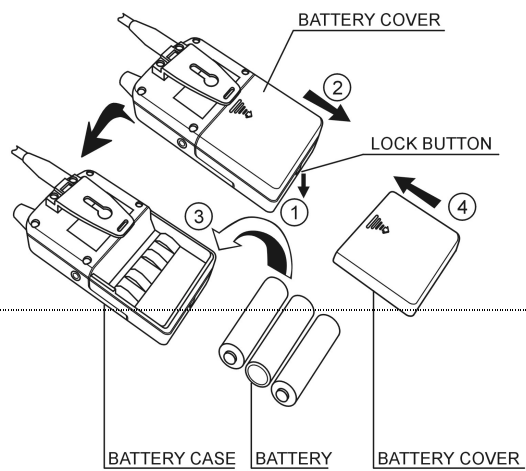

SENSITIVITY ----- FM : 0.5 μ V FOR 12dB SND
AM : 1 μ V for 10dB NQ
SELECTIVITY ----- 50dB Min.
S/N RATIO ----- 40dB Min.
AUDIO OUTPUT @10%THD ---- 150mW 8 Ω , BTL

 **maycom Co., Ltd.**

Maycom B/D, 280-5, Seoksu 2-Dong, Manan-Gu, Anyang-City,
Kyoungki-Do, Korea

Tel) 82 31 470-7700 Fax) 82 31 472-3700

Home page : <http://www.maycomcoltd.com>

<http://www.emaycom.com>

e-mail : maycom@maycomcoltd.com

maycom@emaycom.com

Printed in Korea